

TECHNICAL NOTES

Humidity

Humidity Measurement

Controlling the environment indoors is the primary function of the HVAC industry. Humidity measurement is an important tool for predicting the climate outdoors as well as controlling the climate indoors. Humidity control is especially important in living, storage, and manufacturing sites.

Definitions

Scientifically stated, humidity is the measure of water vapor present in a gas. Vapor is a term that refers to the gaseous form of a substance that normally exists as a solid or liquid. When liquid exists as a gas, it exerts pressure on its surroundings. This pressure determines the amount of vapor in the air at a given temperature. This value, known as *vapor pressure*, varies with temperature and pressure, as well as from substance to substance. Water, for example, has a high vapor pressure at temperatures near boiling (at the boiling point the vapor pressure = the atmospheric pressure). A low vapor pressure at temperatures below freezing (all solids generally have low vapor pressures; if they did not, they would evaporate). The vapor pressure rises as pressure decreases, which explains why water boils at a lower temperature in higher altitudes (low pressure). *Absolute humidity* is a measure of the mass of the water vapor present in a specified volume. Because the mass of water vapor is difficult to measure, a more common measurement called relative humidity is used. *Relative humidity* (RH) is the percentage of the amount of water that the air can hold at a given temperature. The following equation calculates the percent relative humidity.

$$\%RH = \frac{P_a}{P_s} \times 100 \qquad \text{Eq. 1}$$

Where: P_a = actual pressure
 P_s = saturated pressure

Relative Humidity is temperature dependent. At 100% RH, the actual pressure of the water vapor is equal to the saturation pressure. The temperature where this exists is called the *dew point*. Any cooling below the dew point causes water to condense. If the atmosphere stabilizes at a constant humidity during the day, the falling temperatures at night may go below the dew point causing the vapor to condense. The condensing vapor creates the phenomenon commonly known as dew. A crucial fact to note is that it is only necessary for

the sensor to obtain one measurement, absolute humidity, RH, or dew point, because the other two can be calculated using the ambient temperature, graphs or equations.

Sensing Methods

In general, obtaining a measure of humidity is not an easy task. Many of the instruments have poor accuracy, narrow bandwidth, contamination problems, and hysteresis. Some of the instruments are large, awkward, and expensive pieces of equipment. To compound the problem there are few highly accurate devices for humidity generation and measurement, needed for use in sensor calibration. Discussed below, are the different methods of humidity sensing.

Psychrometric Method

The oldest method for measuring relative humidity is the psychrometric method. Psychrometry is commonly known as the “wet” and “dry” bulb method. A psychrometric sensor does not directly sense humidity, but rather it senses temperature to indirectly find relative humidity. The sensing elements can be thermometers, RTD’s, or thermistors. The first sensing element, the dry bulb, measures ambient temperature. The second sensing element, the wet bulb, is enclosed in a wick saturated with distilled water. Air forced across the wet bulb creates evaporation, which cools it below ambient temperature. The amount of evaporation (cooling) is dependent on the vapor pressure of the air. Using the wet and dry bulb temperatures, the relative humidity can be looked up on a psychrometric chart. Looking up the %RH on a chart for every measurement is time-consuming and cumbersome. With today’s technology, psychrometric charts and dew point equations can be stored in a microprocessor, thus making this a direct sensing method for RH and dew point.

The sling psychrometer dates back to the late 19th century. It used mercury thermometers for temperature measurement, and swinging the bulb around created air movement across the wet bulb. Nowadays, the units have built in fans to ventilate the wet bulb. A psychrometric sensor has good precision with %RH resolutions of 0.1%, humidity ranges from 10 - 100% at temperatures from 32°F to 140°F, and accuracy’s of $\pm 2\%$. The drawbacks of a psychrometric sensor are a slow response time and they are substantially more expensive.

Dew Point Method

Another method for measuring humidity is using a dew point sensor. There are two common types of dew point sensors, the cooled condensation surface type, or a solution of saturated lithium chloride. The solution of saturated lithium chloride does not directly sense relative humidity. Saturating a wick with resistive electrodes in the solution and an excitation current through the wick creates joule heating. The heating causes some of the solution to evaporate, which reduces the resistance and slows heating. Eventually equilibrium is reached and the temperature of the solution can then be related to the dew point.

The cooled condensation surface type detects very accurately the temperature at which condensation begins. The most common device used is a mirror to detect for condensation. The system is set up so an LED (light emitting diode) reflects off the mirror at an angle of about 45 degrees. A photo-transistor detects the reflected light. Then, the temperature of the mirror is electronically controlled. The system works by cooling the mirror's surface below the ambient temperature until condensation forms. The condensation on the surface of the mirror causes the LED's light to scatter. The scattered light creates a sudden drop in the output of the photo-transistor. At this point, the surface temperature of the mirror is read using a temperature sensor such as an RTD or thermistor. This temperature is the dew point. With a feedback loop, the cooling or heating of the mirror continuously tracks the dew point. There are a few different designs of condensation surfaces that are also used. The chilled mirror method is the most stable and accurate method to determine relative humidity. It is crucial to keep the mirror clean and ensure the temperature sensor and mirror is of high quality. This method has the best humidity range (0-100%RH) and can be used for numerous gases at many pressures. These instruments are bulky and very expensive.

Hygrometric Method

The hygrometric method of relative humidity sensing is the most common. The instruments are generally compact, reliable, and inexpensive. Hygrometric humidity sensors provide an output that is directly indicative of humidity. The first humidity sensing elements were mechanical in nature. Physical dimensions of various materials will change with the adsorption¹ of water. Some examples of these are hair, animal membrane, and some plastics. To build a sensor from these materials the element is kept in tension with a spring. A strain gage monitors the displacement caused by a change in the moisture content of the air. The output of the strain gage is directly proportional to the relative humidity. A second method of hygrometry is coating an oscillating crystal (quartz) with a hygroscopic coating. When the coating adsorbs water the mass changes which then changes the crystal's oscillating frequency. A more obscure method is an electrolytic hygrometer. This method is complicated and not used frequently enough to warrant explanation.

Recent strides in thin film and micromachining technology make it possible to produce high quality resistive and capacitive hygrometric sensors. These sensors have become more accurate, compact, and stable in recent years making them popular in industry. The materials used to produce these sensing elements have the ability to change their electrical characteristics with the adsorption of water. The materials have changed over the years from electrolytic salts, to ceramics, to the recently popular polymers. The new designs in sensing material have overcome many problems. The first major problem with the sensors was narrow bandwidths. Each individual sensor was only reliable over a span of 10 to 20% relative humidity. Numerous manufactured sensors with specific spans cover the entire %RH span. Then there was a problem when adsorbed water left impurities behind on the surface. These impurities would change the electrical characteristics of the sensing materials. The polymers used now have overcome these early problems.

¹ Adsorb/absorb. Absorption refers to a substance taking in another, like the way a sponge picks up water. Adsorption is when the substance picked up collects on the surface and is not introduced into the bulk of the adsorbing material.

A capacitive sensor is built like a parallel-plate capacitor. The sensing element serves as the dielectric. As the moisture in the air changes the water vapor, the sensing polymer changes with adsorption, resulting in a dielectric constant change. The dielectric constant is directly proportional to the capacitance, which is inversely proportional to the %RH. New techniques in producing thin films have made these, accurate, stable, and easy to manufacture large quantities.

The resistive types of hygrometers are the sensors ACI uses in their products. The sensors consist of placing a thin film of sensing polymer over a set of comb electrodes. Figure 1 is a representation of the physical parts of the humidity sensor. The sensor adsorbs water into the humidity sensing material, which changes the polymers resistance. Other materials adsorb the water, which changes just the surface resistivity. Because the water is absorbed the bulk resistance of the polymer changes making the sensor resistant to surface contamination. The sensor requires an AC excitation current. So there is no chance electrolysis or separation of the humidity-sensing polymer can occur. Thin film technology makes these sensors accurate, stable, and easy to manufacture. The choice of material assures they have fast response times with little hysteresis. Another attraction is their small size and low cost.

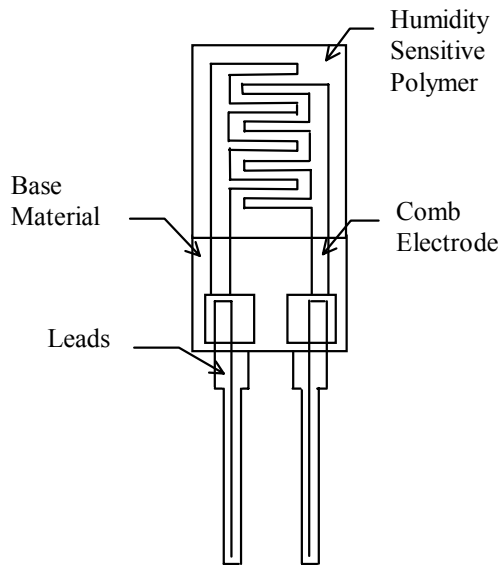

Figure 1: Front view of the construction of a bulk polymer resistive type humidity sensor.

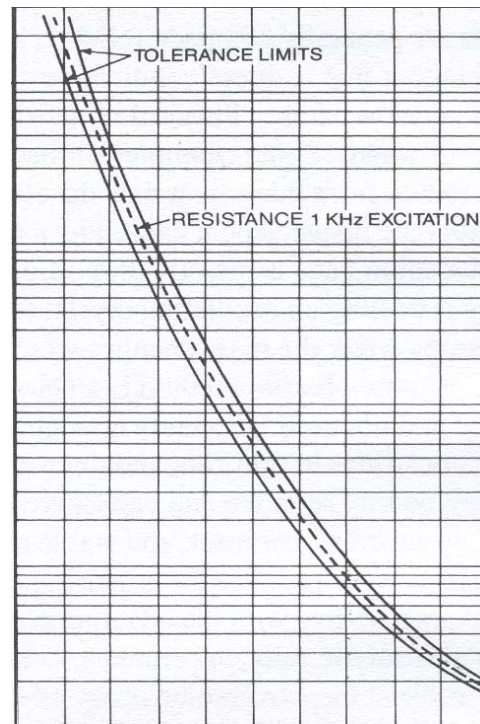

Figure 2: The resistance versus relative humidity curve for a bulk polymer resistive sensor.

Product Specifications

A high quality sensor requires a high degree of stability, accuracy, linearity, and bandwidth. Ultimately, there should be little hysteresis and a short response time. The humidity sensors supplied with ACI's products are strong in all these qualities.

The humidity sensor that ACI uses overcomes the limitations of other resistance-based humidity sensors that utilize water soluble polymer coatings. Advanced ceramic technology enables these sensors to recover fully from condensation. The sensor consists of a ceramic substrate with interdigitated metal alloy electrodes. This substrate is then coated with a proprietary hygroscopic conductive ceramic material. Since the ceramic is not water soluble, the sensor recovers from condensation or from direct water contact. Which means, consumers can rely on high accuracy and interchangeability at a competitive cost.

The accuracy of the sensor we use is $\pm 2\%$ RH and verified to NIST traceable humidity standards. A precision environmental chamber and computerized data acquisition system verifies the performance of each sensor. Other resistive humidity sensors typically have a $\pm 5\%$ RH accuracy. The sensors operating range of (0-100% RH from -20 to +160 degrees F) includes temperatures below freezing and %RH above 95%, where other water-soluble substrates fail. The accuracy specified is between (20-95% RH at 77 degrees F). Figure 2 is a plot of the resistance of the sensor versus the relative humidity. The sensor itself responds logarithmically to humidity and then the transmitter electronics linearizes the signal throughout the sensors operating range. The transmitter electronics provides an accurate, linear output from 0 to 100% RH.

All the transmitter electronics use industrial standard components. An industrial standard component operates at temperatures below freezing. These components utilize the temperature range of the humidity sensor. The transmitter design accurately calculates the sensors logarithmic response with a microprocessor-based system. The microprocessor design replaces many analog components, which in return reduces the cost. At the same time accuracy is improved because the microprocessor can calculate the actual logarithmic curve of the sensor. In the past, an analog logarithmic op-amp circuit accomplished this.

Humidity changes with respect to temperature; however, temperature compensation overcomes these effects to the sensor. Most relative humidity circuits use a temperature compensating diode. This component adjusts the voltage to a logarithmic op-amp circuit with respect to temperature. The ACI/RH design uses a thermistor to calculate the actual temperature. The temperature coefficient for the ACI/RH sensor (-0.7% RH / degree C).

A precision environmental chamber verifies the accuracy of every ACI/RH transmitter board prior to shipping. This environmental chamber is an NIST traceable humidity standard.

ACI sells three types of humidity transmitters incorporating the resistive humidity sensor. The ACI/RH-2 is accurate to $\pm 2\%$ RH, the ACI/RH-3 is accurate to $\pm 3\%$ RH, and the ACI/RH-5 is accurate to $\pm 5\%$ RH. The accuracy is valid over the range (20 - 95% RH) and is calculated taking into account hysteresis, non-linearity, and repeatability. The humidity transmitter is sensitive to 0.1% RH over the entire operating span (0-100% RH). The sensor has excellent stability with less than 2% drift in five years.

Environmental Tests

TEST	CONDITIONS	TIME	CHANGE IN %RH
1. Low temperature (0° C)	At 0° C in moisture proof bag	17 months	-1.4% RH
2. Low temperature resistance	At -20° C in moisture proof bag	1000 hours	+1% RH
3. Normal temperature (25° C)	In 25° C dryer, 1 volt rms applied	24 months	+2.1% RH
4. High temperature (50° C)	In 50° C dryer, 1 volt rms applied	24 months	+3.0% RH
5. Resistance to heat (80° C)	In 80° C dryer, 1 volt rms applied	5 months	+6.1% RH
6. Resistance to heat (100° C)	In 100° C dryer	20 days	+6.2% RH
7. Heat resistance	At 120° C in dessiccator	1000 hours	+2% RH
8. Temperature cycle test	0° C (30 min.) + 100° C (30 min.)	4000 cycles	-0.4% RH
9. Temperature cycle	-20° C (30 min.) + 100° C (30 min.)	100 times	+ 2% RH
10. Resistance to humidity (25° C, 90% RH)	25° C, 90% RH in tank, 1 volt rms applied	13 months	+3.0% RH
11. Humidity cycle	10% RH (30 min.) + 90 % RH (30 min.) Repeat cycle @ 25° C	1000 times	+2% RH
12. High temperature and high humidity	50° C, 80% RH in tank 1 volt rms applied	12 months	6.3% RH
13. Standing at high temperature and high humidity	99.9% RH and 60° C	1000 hours	+2% RH
14. Standing at low humidity	20% RH or under at room temperature	2000 hours	+1% RH
15. Humidity cycle	25° C, 40% RH (30 min.) 90% RH (30 min.)	2000 cycles	+3.5% RH
16. Condensation cycle	0% RH (10 min.) 100% RH (20 min.) Repeat at 40° C	1000 times	+2% RH
17. Storage test	Left in room in sealed (silica gel) bag	23 months	+2.1% RH
18. Resistance to gas (saturated acetone)	Saturated acetone atmosphere	6 months	+0.1% RH
19. Resistance to gas (saturated ammonia)	Saturated ammonia gas, 1 volt rms applied	9 days	-4.6% RH
20. Resistance to gas (saturated formalin)	Formalin gas at room temperature	2 months	+1.8% RH
21. Resistance to gas (saturated NaCl)	NaCl saturated solution at room temperature	5 months	+2.3% RH
22. Saturated water vapor	Water vapor at room temperature	5 months	+2.5% RH
23. Resistance to oil smoke	Atmosphere saturated with mosquito repellent incense smoke	1 stick	+1.6% RH
24. Resistance to oil	Apply salad oil by brush	One time	0% RH
25. Resistance to oil	Impregnated with cooking oil	After 1 min.	+1.7% RH
26. Solder heat resistance	350° C, 5 sec.	2 times	+1% RH
27. Water immersion	Room temperature	3 min.	+5% RH
28. Resistance to organic solvents	Stand in solution of benzene 30%, toluene 30%, and xylene 40%	2000 hours	+1% RH
29. Resistance to formalin	Stand in solution of 10% formalin	300 hours	+1% RH
30. Resistance to alcohol	50% ethanol 50% methanol	300 hours 300 hours	+2% RH
31. Resistance to tobacco	Stand in a solution of 3 cigarettes (1000 ml)	60 min.	+1% RH